

Single-Family Stairs & Railings

Width

Stairways shall not be less than 36 inches wide. Handrails may encroach a maximum of 4 1/2 inches into the required stair width. Stairs wider than 60 inches require handrails on both sides. Monolithic stairs require handrails at intervals not to exceed 60" (5 feet).

Continuity

The largest tread depth or riser height for any stair shall not vary more than 3/8 of an inch from the smallest tread depth or riser height.

Treads, Risers & Nosings

The minimum tread depth as measured from nosing-to-nosing shall not be less than 10 inches. The maximum height between treads shall not be greater than 7 3/4 inches. Each tread shall have a nosing not less than 3/4" and not greater than 1 1/4". *

*Exception: Nosings are not required on treads greater than 11 inches where the risers are closed.

Headroom

Every stairway shall have a minimum clearance for headroom of 6 feet 8 inches as measured up from the nosing of any tread.

Handrails & Guards

Handrails are required for 4 or more risers. Handrails shall be continuous for the full length of any stair from a point above the top and bottom risers.* Handrail ends must be returned back into walls or rails. Handrails may stop at minimum 3 feet x 3 feet landings.

*Exceptions:

1. Handrails may be interrupted at a newel post at a turn.
2. A volute or turnout is permitted over the lowest tread.

Handrail grip requirements are listed on the next page

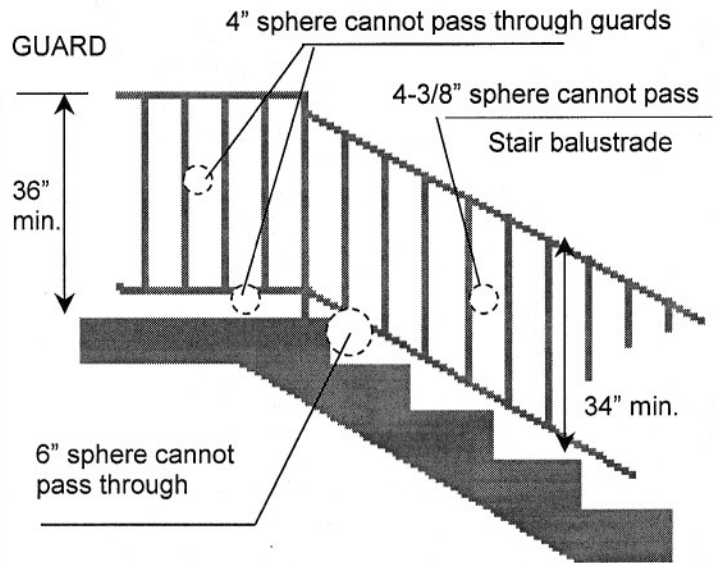

Rail Heights & Opening Limitations

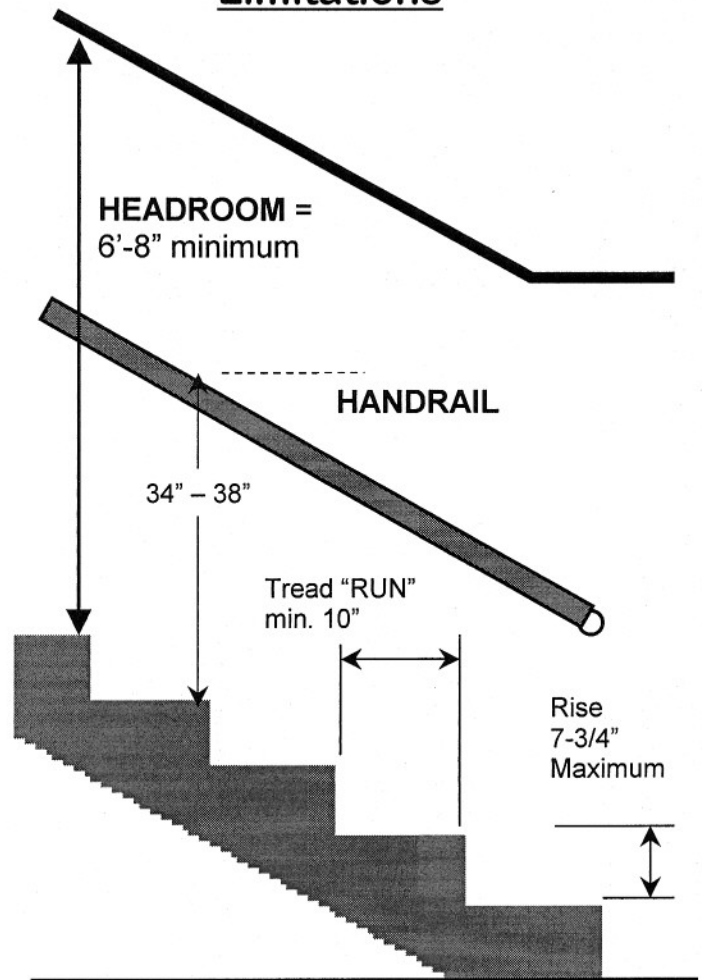

NOTE: REQUIRED HANDRAILS ARE NOT SHOWN

